

solo[®]

Piston Pump Repair Kit (0610407-K)

Tools needed for the installation of parts:

- | | |
|---------------------------------|---|
| 6 mm Allen Head Wrench | 13 mm Socket or Wrench |
| Flat Head Screwdriver | T-25 Torx Screwdriver |
| 11 mm Wrench or Crescent Wrench | Grease (Vaseline [®] or Petroleum Jelly) |
| Long Nose Pliers | 2x4 piece of wood 18" long |
| Heavy Hammer | |

SAFETY PRECAUTIONS:

1. Always wear rubber gloves, safety goggles and appropriate protective clothing when repairing a sprayer.
2. Work in a well ventilated area.
3. Prior to repair, thoroughly flush the sprayer with water. Next, fill the tank and pump the water through the sprayer and discharge out the end of the wand into an appropriate container or area.
4. Ensure all pressure in the sprayer is relieved by locking the shut-off valve in the open position.

PROCEDURE:

1. Remove the two handle bolts and set handle and bolts aside.
2. Loosen, but do not remove the stop plate (17).
3. Remove the nut and bolt in the protective cover (51), then remove the protective cover from the piston cylinder (40).
4. Remove the two 6 mm Allen head bolts (2) from the lever (42). Rotate the pump shaft (18) as necessary to access the bolts. Pull the piston (43) out of the piston cylinder and replace the Viton[®] Collar (44). Grease the Viton[®] Collar with Vaseline[®].
5. Unscrew the piston cylinder by rotating counter clockwise.
6. Remove the two O-rings (12 & 13) on the piston cylinder and replace, making sure the O-rings fit into the grooves securely.
7. Remove the valve plate (20) on the top of the piston cylinder and replace it.
8. Replace the valve plate held in by the red retaining pin on the inside of the piston cylinder. Use long nose pliers to remove and replace the pin and the new valve plate.
9. To replace the large O-ring (11) on the pressure cylinder (39), the cylinder will need to be removed from the tank. **Note: The cylinder will only need to be removed if this O-ring needs to be replaced. If you do not need to replace the large O-ring, move to instruction 11.**
10. To remove the pressure cylinder, first remove the pump shaft (18). Remove the black clamp (16) located at the opening at the bottom of tank. Remove the control knob (16) and valve body (23) from the top of the cylinder by turning counterclockwise. To protect the pressure cylinder, place a rag over the top. Using the 2x4 and heavy hammer, forcibly knock the cylinder out through the bottom of the tank. Replace the large O-ring by sliding it over the top of the pressure cylinder. Ensure that it is seated in the groove.

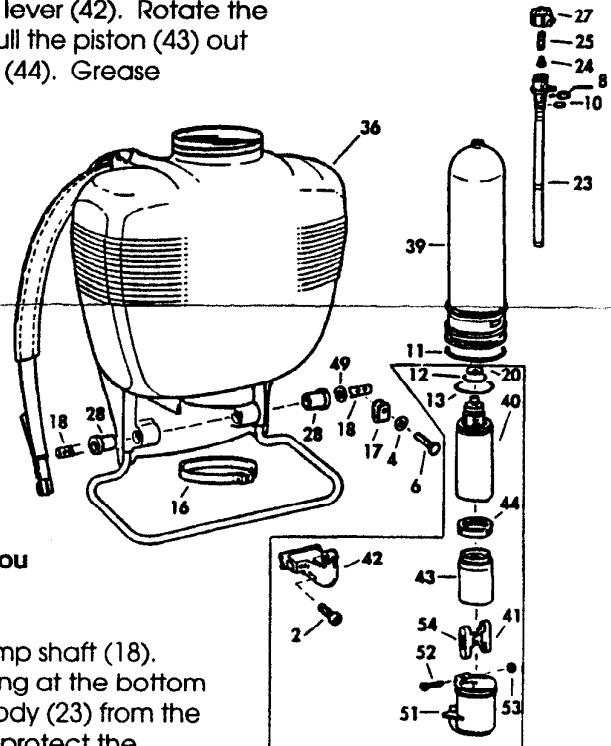

11. Remove the spring (25) and seal plug (24) from control knob and replace with those in the repair kit. Next remove and replace both O-rings (8 & 10) on valve body. Reinstall the valve body and control knob.
12. Reassemble the piston cylinder to the pressure cylinder by turning clockwise. Ensure the tab on the pressure cylinder is aligned with the notch on the piston cylinder.
13. If removed, insert the pressure cylinder back in to the tank using the 2x4. Place 2x4 between the frame and piston cylinder and push pressure cylinder down until large O-ring is flush in the tank. Make sure O-ring does not become pinched between the tank and pressure cylinder.
14. Reassemble clamp to opening at bottom of the tank and pressure cylinder.
15. Grease the inside of the piston cylinder with Vaseline® before installing piston.
16. Reinstall the pump shaft (18).
17. Tighten the lever (42) to the pump shaft using the two 6 mm Allen head bolts.
18. Retighten the stop plate.
19. Reattach the handle with the two 13 mm bolts and washers.
20. Fill the formula tank with water only and make sure there are no leaks. Pressurize the sprayer to make sure there are no leaks and that all components are functioning properly. **Do not use the sprayer until all components are leak free and functioning properly.**

Hint: Vaseline® applied to O-rings will help in reassembling.

Order No.	Description	ReferenceNo.
4400189	Viton® Collar	44
0062138	O-ring	11
0062139	O-ring	12
0062140	O-ring	13
4061257 x 2	Valve Plate	20
0062115	O-ring	8
0070260	Spring	25
4074350	Sealing Plug	24
0062258	O-ring	10

